

  
**DIAMOND**<sup>®</sup>  
DIAMOND CHAIN COMPANY



MAINTENANCE GUIDE



## TABLE OF CONTENTS

Installation	4
Lubrication	5-6
Inspections	7
Elongation Limits	8
Troubleshooting	9-10
Instructions	11

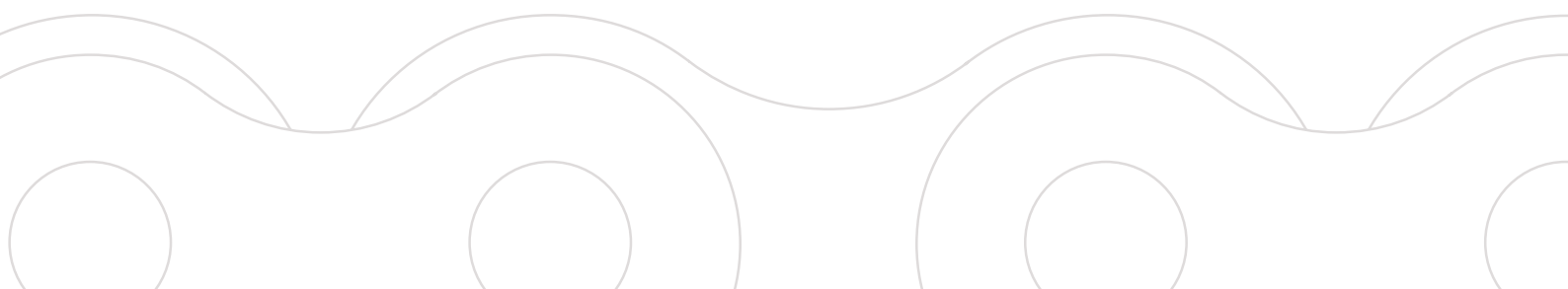

*Every Calling is Great, When Greatly Pursued.*

OLIVER WENDELL HOLMES



At the Diamond Chain Company, the calling to design and manufacture the world's highest-performing roller chain is greatly pursued every day by teams of passionate technical experts who have made your success their life's work. It's that intensity of focus that some of the world's greatest inventors trusted to provide the drive chains they needed to transform the world. From the Wright Brothers, to Henry Ford, to the global leaders of our time, Diamond® chain is the roller chain most trusted to perform, when performance matters most.

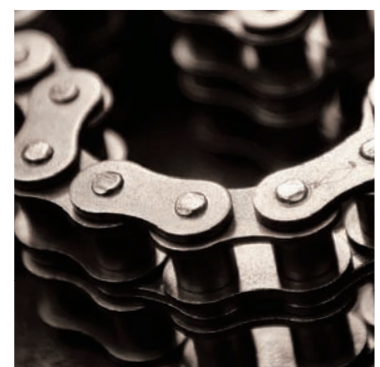

## INSTALLATION

To obtain maximum service-life and efficiency from a chain drive, it is necessary that certain precautions in installation be taken. Chain drive installation is relatively simple and good results may be obtained when the following conditions are met:

1. The roller chain, sprockets, and other components are in good condition.
2. The sprockets are properly aligned.
3. Provision is made for adequate lubrication.
4. The chain is correctly tensioned.

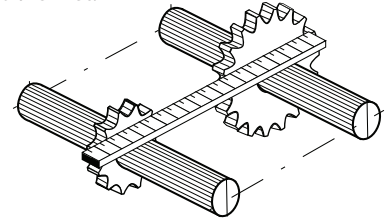

## CONDITION OF COMPONENTS

Shafting, bearings, and foundations should be supported rigidly to maintain the initial alignment. Roller chain should be free of grit and dirt. Wash chain in kerosene when required and then **re-lubricate**.

## DRIVE ALIGNMENT

Misalignment results in uneven loading across the width of the chain and may cause roller linkplate and sprocket tooth wear. Drive alignment involves two things: parallel shaft alignment and sprocket axial alignment.

1. Shafts should be parallel and level. This condition may be readily checked by the use of a feeler bar, and a machinist's level. If there is axial movement of the shaft (as in the case of an electric motor), lock the shaft in the normal running position before aligning the sprockets.

Most single strand drives will perform acceptably if the shafts are parallel and in the same plane within .050 in/ft (4.2 mm/m) or 1/4°. However, high speed, high horsepower, or multiple strand drives should be aligned within the tolerance obtained from the following formula:

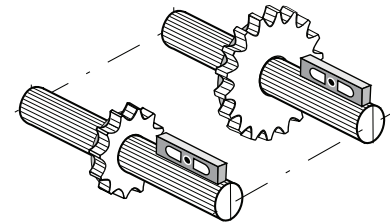

$$\text{Tolerance} = \frac{.00133 C}{P n} \text{ (in/ft), or } \frac{.111 C}{P n} \text{ (mm/m)}$$

Where: C = center distance, in inches or mm.  
P = chain pitch, in inches or mm.  
n = number of chain strands.

2. Sprocket axial alignment can be checked with a straight edge which will extend across the finished sides of the two sprockets. Normally, it is good practice to align the sprockets as close to the shaft bearing as possible. For long center distances, use a taut cord, or wire long enough to extend beyond each of the sprockets. The maximum allowable amount of axial misalignment is obtained from the following formula:

Max. Offset = 0.045 P in inches or mm where P = chain pitch in inches or mm. This formula applies to both single and multiple strand chains.

## INSTALLING THE CHAIN

Re-check all preceding adjustments for alignment and make certain all set screws, bolts and nuts are tight. Fit chain around both sprockets and bring the free ends together on one sprocket for connection. The sprocket teeth will locate the chain end links. Install the connecting link and connecting link coverplate, and the spring clip or cotter pins. On larger pitch or heavy multiple strand chains, it may be necessary to lock the sprockets for this operation. When press fit coverplates are used, be careful not to drive the plate on so far as to grip the roller links. Stiff joints can result if this is done. On drives with long spans, it may be necessary to support the chain with a plank or bar as the connection is made.

## CHAIN TENSION

Check chain tension to be certain the slack span has 4-6% mid-span movement in horizontal drives and 2-3% in vertical drives. Please reference the table below.

Recommended Possible Mid-Span Movement AC

Drive Center-Line	Tangent Length Between Sprockets								
	127 mm	254 mm	381 mm	508 mm	762 mm	1016 mm	1524 mm	2032 mm	2540 mm
Horizontal to 45°	6.35	12.7	19.05	25.4	38.1	50.8	76.2	101.6	127
Vertical to 45°	3.048	6.35	9.652	12.7	19.05	25.4	38.1	50.8	63.5

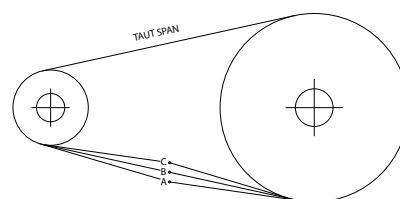

AC = Total Possible Mid-Span Movement

## LUBRICATION

Roller chain consists of a series of connected traveling metallic bearings which must be properly lubricated to obtain the maximum service life of the chain. Although many slow speed drives operate successfully with little or no lubrication beyond the initial factory lubrication, proper lubrication will greatly extend the useful life of every chain drive. The chain drive requires lubrication for six purposes:

1. To resist wear of the pin-bushing joint.
2. To cushion impact loads.
3. To dissipate any heat generated.
4. To flush away foreign materials.
5. To lubricate chain-sprocket contact surfaces.
6. To retard rust or corrosion.

A good grade of clean petroleum oil without additives, free flowing at the prevailing temperatures, should be used. Some additives leave a varnish or gum deposit which prevents the oil from entering chain joints. Heavy oils and greases are generally too stiff to enter the chain joints and should not be used.

With proper lubrication, a separating wedge of lubrication is formed between the pins and bushings in the chain joints much like that formed in journal bearings. The viscosity of the lubricant greatly affects its film strength, and its ability to separate moving parts. The highest viscosity oil which will flow between the chain linkplates and fill the pin-bushing areas will provide the best wear life. This is essential to minimize metal to metal contact and, if supplied in sufficient volume, the lubricant also provides effective cooling and impact dampening at higher speeds.

*Note: Speeds beyond the maximum recommended for chain operation are indicated in the horsepower rating tables with zero horsepower. Operation at these or higher speeds will result in excessive galling of the chain pins and bushings regardless of the volume of oil applied.*

Chain drives should be protected from abrasive and corrosive conditions and the oil supply kept free of contamination. Periodic oil changes are encouraged.

*Note: Oil should be applied to the lower span of chain on the upper edges of linkplates since access of oil to pin-bushing joints is possible only through the clearances between the roller chain linkplates.*

Oil applied to rollers only cannot reach pin-bushing joints, and therefore, cannot retard chain elongation due to wear. The lengthening of chains in service results from wear on pin and bushing surfaces, not rollers. When lubricating multiple strand chain, it is important that lubricant be directed to each row of chain linkplates. In conveyor applications, oil should be directed between the rollers and bushings as well as between the chain linkplates.

The table indicates the lubricant viscosity recommended for various surrounding temperatures:

There are three basic types of lubrication for roller chain drives. Close adherence to the recommended type of lubrication is essential to obtaining maximum service life of a chain drive.

The recommended type of lubrication as shown in the horsepower rating tables is determined by the chain speed and the amount of power transmitted.

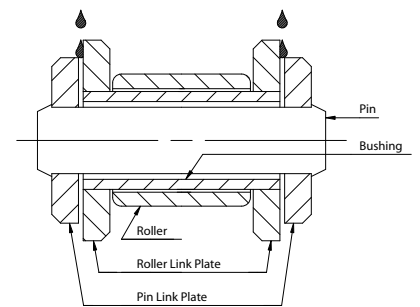

Recommended Grade	Operating Temperature °C
SAE 5	-46 TO +10
SAE 10	-29 TO +27
SAE 20	-12 TO +43
SAE 30	-7 TO +54
SAE 40	-1 TO +60
SAE 50	+4 TO +65

## MANUAL OR DRIP LUBRICATION (TYPE A)

Oil should be applied periodically between the chain linkplate edges with a brush, spout can, or drip lubrication.

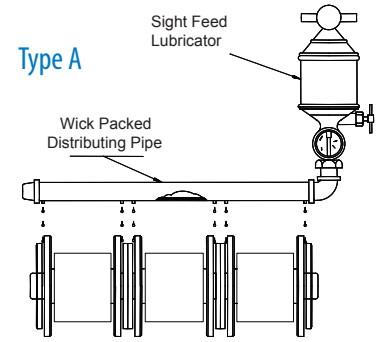

## OIL BATH OR OIL SLINGER (TYPE B)

With bath lubrication, the lower strand of chain runs through a sump of oil in the drive housing. The oil level should reach the pitch line of the chain at its lowest point while operating. Only a short length of chain should run through the oil.

Drive arrangements which permit long length of chain to travel through the oil should be avoided as overheating or foaming may result.

With slinger disc lubrication, the chain operates above the oil level. The disc picks up oil from the sump and deposits it into the chain, usually by means of a trough. The diameter of the disc should produce rim speeds between 183 Meters/Min. minimum and 2438 Meters/Min. maximum. A collector plate is usually required to direct the oil to the chain linkplates.

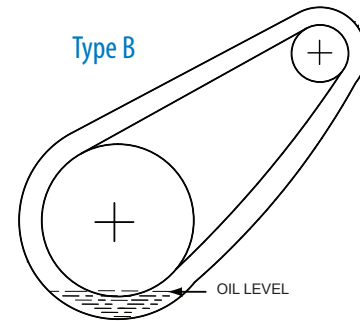

## OIL STREAM LUBRICATION (TYPE C)

This type of lubrication is required for large horsepower, high speed drives. An oil pump should be provided to spray the oil across the lower span of chain in a continuous stream. Orifices should be placed so that oil is sprayed across each strand of the chain. This type of lubrication may be used up to the maximum speeds shown in the horsepower rating tables for each size of chain, except where the rating is zero.

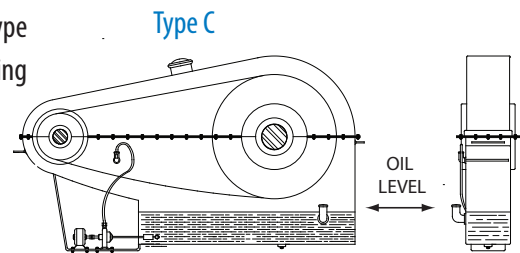

Limiting Chain Speed for Various Types of Lubrication (Chain Speed in Meters/Minute)

Chain No.	35/06B	40/08B	50/10B	60/12B	80/16B	100/20B	120/24B	140/28B	160/32B	200/40B
Type A	106.7	91.4	76.2	65.5	50.3	44.2	38.1	33.5	30.5	24.4
Type B	807.7	670.6	579.1	533.4	449.6	381.0	356.6	320.0	304.8	263.7
Type C	Use for speeds higher than Type B limits.									

## INSPECTIONS

All chain drives should receive regular maintenance. Each drive should be inspected after the initial 100 hours of operation. Thereafter, most drives may be inspected at 500 hour intervals. However, drives subject to shock loads or severe operating conditions should be inspected at 200 hour intervals.

At each inspection, the following items should be checked and corrected, if necessary:

1. **Check lubrication** — On slow speed drives, where manual lubrication is used, be sure the lubrication schedule is being followed. If the chain is covered with dirt and debris, clean the chain with kerosene and **re-lubricate it**.

**WARNING! NEVER USE GASOLINE OR OTHER HIGHLY FLAMMABLE SOLVENTS TO CLEAN A CHAIN. A FIRE MAY RESULT.**

If drip lubrication is used, check for adequate oil flow and proper application to the chain. With bath or pump lubrication, check oil level and add oil if needed. Check oil for contamination and change oil if needed. Change oil after the first 100 hours of operation and each 500 hours thereafter. If pump lubrication is used, check each orifice to be sure it is clear and is directing oil onto the chain properly.

2. **Check Chain Tension** — Check chain tension and adjust as needed to maintain the proper sag in the slack span. If elongation exceeds the available adjustment, remove two pitches and reconnect the chain.

3. **Check Chain Wear** — Measure the chain wear elongation and if elongation exceeds functional limits or is greater than 3% (.001 mm in one meter) replace the entire chain. Do not connect a new section of chain to a worn chain because it may run rough and damage the drive. Do not continue to run a chain worn beyond 3% elongation because the chain will not engage the sprockets properly and it may damage the sprockets.

**NOTE: Diamond Chain wear gauges are available to monitor chain elongation.**

4. **Check Sprocket Tooth Wear** — Check for roughness or binding when the chain engages or disengages from the sprocket. Inspect the sprocket teeth for reduced tooth section and hooked tooth tips. If these conditions are present, the sprocket teeth are excessively worn and the sprocket should be replaced. Do not run new chain on worn sprockets as it will cause the new chain to wear rapidly. Conversely, do not run a worn chain on new sprockets as it will cause the new sprockets to wear rapidly.

5. **Check Sprocket Alignment** — If there is noticeable wear on the inside surface of the chain roller linkplates, the sprockets may be misaligned. Realign the sprockets as outlined in the installation instructions to prevent further abnormal chain and sprocket wear.

6. **Check for Drive Interference** — Check for interference between the drive and other parts of the equipment. If there is any, correct it immediately. Interference can cause abnormal and potentially destructive wear on the chain or the interferring part. If the edges of the chain linkplates impact against a rigid part, linkplate fatigue and chain failure can result.

*NOTE: Check for and eliminate any buildup of debris or foreign material between the chain and sprockets. A RELATIVELY SMALL AMOUNT OF DEBRIS IN THE SPROCKET ROLL SEAT CAN CAUSE TENSILE LOADS GREAT ENOUGH TO BREAK THE CHAIN IF FORCED THROUGH THE DRIVE.*

7. **Check for Failure** — Inspect the chain for cracked, broken, or deformed parts. If any of these conditions are found, REPLACE THE ENTIRE CHAIN, even though portions of the chain appear to be in good condition. In all likelihood, the entire chain has been damaged.

*For additional technical assistance, please contact Diamond Chain at +44-191-414-8822 or at [www.diamondchain.co.uk](http://www.diamondchain.co.uk).*

# ELONGATION LIMITS

## FOR REFERENCE ONLY

3.0% Max. Elongation Adjustable Center Distance Drives

1.5% Max. Elongation Fixed Center Distance Drives

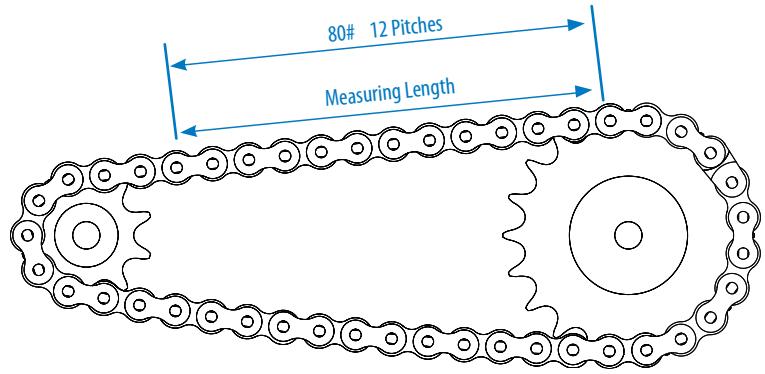

**NOTE: Chain Wear Scales are available free from any Diamond Sales Representative.**



Chain Wear Elongation Limits							
ANSI Chain No.	Chain Pitch		Measured Length				
			Pitches	Nominal		At 3% Wear	
	in	mm			in	mm	in
25	.250	6.35	48	12.00	305	12.375	314
35	.375	9.52	32	12.00	305	12.375	314
41	.500	12.70	24	12.00	305	12.375	314
40	.500	12.70	24	12.00	305	12.375	314
50	.625	15.88	20	12.50	318	12.875	327
60	.750	19.05	16	12.00	305	12.375	314
80	1.000	25.40	12	12.00	305	12.375	314
100	1.250	31.75	20	25.00	635	25.750	654
120	1.500	38.10	16	24.00	610	24.719	628
140	1.750	44.45	14	24.50	622	25.250	641
160	2.000	50.80	12	24.00	610	24.719	628
180	2.250	57.15	12	27.00	686	27.812	706
200	2.500	63.50	10	25.00	635	25.750	654
240	3.000	76.20	8	24.00	610	24.719	628

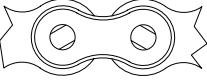
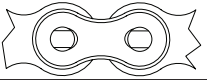
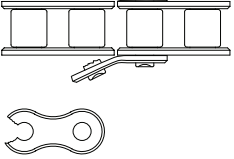

# TROUBLESHOOTING GUIDE

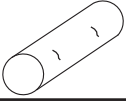
CONDITION/SYMPTOM	POSSIBLE CAUSE	WHAT TO DO
Tight Joints 	Dirt or foreign material in chain joints. Inadequate lubrication. Misalignment. Internal corrosion or rust. Overload bends pins or spreads roller linkplates.	Clean and re-lubricate chain. Replace chain. Re-establish proper lubrication. Replace sprockets and chain if needed. Realign sprockets. Replace chain. Eliminate cause of corrosion or protect chain. Replace chain. Eliminate cause of overload.
Rusted Chain	Exposed to moisture. Water in lubricant. Inadequate lubrication.	Replace chain. Protect from moisture. Change lubricant. Protect lubrication system from water. Replace chain. Provide or re-establish proper lubrication. Replace chain if needed.
Turned Pins 	Overload. Inadequate lubrication.	Replace chain. Eliminate cause of overload. Replace chain. Re-establish proper lubrication.
Enlarged Holes 	Overload.	Replace chain. Eliminate cause of overload.
Broken Pins Broken Linkplates 	Extreme Overload.	Replace chain. Replace sprockets if indicated. Eliminate cause of overload or redesign drive for larger pitch chain.
Broken, Cracked, or Deformed Rollers 	Speed too high. Sprockets too small. Chain riding too high on sprocket teeth.	Replace chain. Reduce speed. Replace chain. Use larger sprockets, or possibly redesign drive for smaller pitch chain. Replace chain. Re-tension chain more often.
Pin Galling 	Speed or load too high. Inadequate lubrication.	Reduce speed or load. Possibly redesign drive for smaller pitch chain. Provide or re-establish proper lubrication.
Chain Climbs Sprocket Teeth	Excess chain slack. Excessive chain wear. Excessive sprocket wear. Excessive overload.	Re-tension chain. Replace and re-tension chain. Replace sprockets and chain. Replace chain. Eliminate cause of overload.

# TROUBLESHOOTING GUIDE

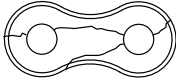
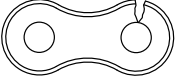
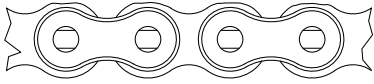
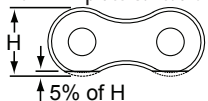
CONDITION/SYMPTOM	POSSIBLE CAUSE	WHAT TO DO
Missing or Broken Cotters	Cotters installed improperly. Vibration. Excessively high speed.	Install new cotters per manufacturer's instructions. Replace chain. Reduce vibration. Use larger sprockets. Replace chain. Reduce speed. Redesign drive for smaller pitch chain.
Exposed Chain Surfaces Corroded or Pitted	Exposure to corrosive environment.	Replace chain. Protect from hostile environment.
Cracked Linkplates (Stress Corrosion) 	Exposure to corrosive environment combined with stress from press fits.	Replace chain. Protect from hostile environment.
Cracked Linkplates (Fatigue) 	Load is greater than chain's dynamic capacity.	Replace chain. Reduce dynamic loading or redesign drive for larger chain.
Battered Linkplate Edges 	Chain striking an obstruction.	Replace chain. Eliminate interference.
Worn Linkplate Contours 	Chain rubbing on casing, guide, or obstruction.	Replace chain if 5% or more of height worn away. Re-tension chain. Eliminate interference.
Excessive Noise	Chain striking an obstruction. Loose casing or shaft mounts. Excess chain slack. Excessive sprocket wear. Sprocket misalignment. Inadequate lubrication. Chain pitch too large Too few sprocket teeth.	Replace chain. Eliminate interference. Tighten fasteners. Re-tension chain. Replace and re-tension chain. Replace chain and sprockets, if needed. Realign sprockets. Replace chain if needed. Re-establish proper lubrication. Redesign drive for smaller pitch chain. Check to see if larger sprockets can be used. If not, redesign drive.
Wear on Inside of Roller Linkplates and One Side of Sprockets	Sprocket misalignment.	Replace sprockets and chain if needed. Realign drive. Re-tension chain.
Chain Clings to Sprocket	Excessive sprocket wear. Sprocket misalignment.	Replace sprockets and chain. Replace sprockets and chain if needed. Realign sprockets.

# INSTRUCTIONS

## WHEN DISASSEMBLING OR ASSEMBLING CHAINS:

**WARNING** — The components of a chain are hardened parts. Striking these parts may cause metal chips to break off from the chain or the tools used resulting in personal injury. During all stages of chain assembly and disassembly, **wear safety glasses** to prevent metal parts or chips from entering your eyes and have personnel in the immediate area do likewise.

### A. Pin Removal

- 1) If chain is of cotterpin-type construction, remove cotters.
- 2) If chain is riveted-type construction, grind pin heads off so pin ends are flush with the linkplate.
- 3) Drive pins out of linkplate using a Diamond pin extractor Model #113 or #135. Some multiple strand chains or large pitch models will require a hammer and punch or a press to remove the pins.

### B. Installation of Coversides

Diamond coversides are manufactured three different ways: (1) Slip Fit, (2) Modified Press Fit, and (3) Full Press Fit. Modified and full press fits require some patience and tools to assemble and/or disassemble.

#### Full Press-Fit and Modified Press-Fit Coversides

To assemble the press-fit coversides:

1. Insert the “Master Link,” the portion of the link that contains the pins, and provide support or backing to resist the forces needed to drive the coverside on.
2. Place the press-fit coverside over the exposed pin ends and ensure that it is aligned properly.
3. Drive the coverside on until it is flush with the ends of the pins.
4. Obtain a hollow punch (perhaps a small piece of pipe or a discarded chain’s roller) and locate it over/around the flush pin end.
5. Alternately from one pitch hole to the other, continue to drive the ends of the link plate onto the pins until it is clear of the spring clip groove or cotter hole. Care should be taken not to drive the plate on so far as to squeeze against or pinch the roller links. This will result in stiff or binding joints.
6. Install the retaining device, either spring clip or cotter.

**Caution: Never drill out or enlarge the pitch holes of a press-fit coverside to make the installation easier. This will lower the integrity of the link.**

#### Slip-Fit Coversides

To assemble the slip-fit coversides:

1. Insert the “Master Link,” the portion of the link that contains the pins, into the chain.
2. Slide the plate over the pin ends to a location which clears either the spring clip groove or cotter hole
3. Install the retaining device, either spring clip or cotter.

**Note: When a slip-fit coverside is used, a chain’s working capacity can be reduced as much as 30%.**

### C. Installation of Spring Clips and Cotterspines

After coverside has been installed, install spring clips or cotters (depending on chain design). Avoid using bent or worn cotters or spring clips. After spring clips (or cotters) are installed, lightly tap pin ends to position these parts snug against the coverside for additional support.

## WHEN INSTALLING CHAIN DRIVES ON EQUIPMENT:

**WARNING** — You may be seriously injured if you attempt to install chain on equipment under power. Shut off power and lock out gears and sprockets before attempting installation.

Once installed, the chain drive must be guarded to prevent personal injury or property damage in the event the chain separates during operation. If chain drive is not guarded, contact equipment manufacturer for recommendations on guarding before using equipment.

# DIAMOND<sup>®</sup> CHAIN COMPANY

## Americas

Corporate Headquarters  
402 Kentucky Avenue  
Indianapolis, Indiana 46225  
PH: 1-800 US CHAIN  
1-800-872-4246  
Fax: 1-317-613-2243

Dallas Service Center  
9120 Premier Row  
Dallas, Texas 75356  
PH: 1-800-872-4246  
Fax: 1-214-631-2374

Sacramento Service Center  
1331 Terminal St  
West Sacramento, CA 95691  
PH: 1-800-872-4246  
Fax: 1-916-372-5801  
sales@diamondchain.com

Canada/Mexico  
PH: 1-317-638-6431  
www.diamondchain.com

## United Kingdom

Unit 7 – 9  
Blaydon Industrial Park  
Chainbridge Road  
Blaydon on Tyne  
NE21 5AB  
PH: +44-191-414-8822  
sales@diamondchain.co.uk  
www.diamondchain.co.uk

## Asia

Century Financial Tower, Unit 2005  
No. 1 Suhua Road, SIP, Suzhou  
Jiangsu Province, China 215021  
PH: +86-512-6265-3075  
salescn@diamondchain.com

